

BELT CONVEYOR HEAVY DUTY SLIDER BED MODEL SB650

Applications

- Packing
- Inspecting
- Sorting
- Transporting
- Assembling
- Testing

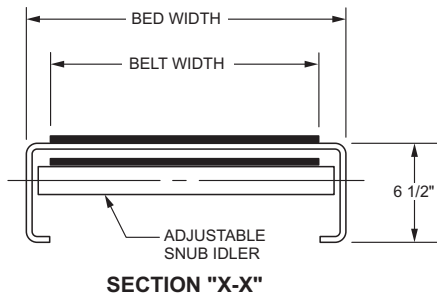
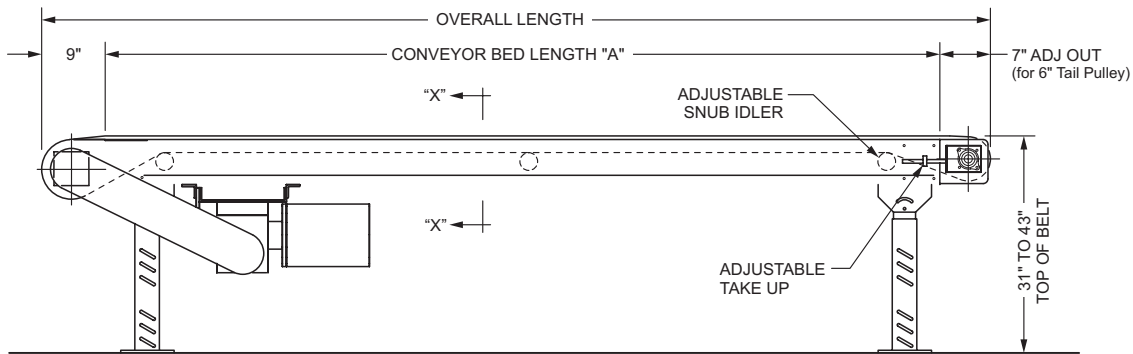
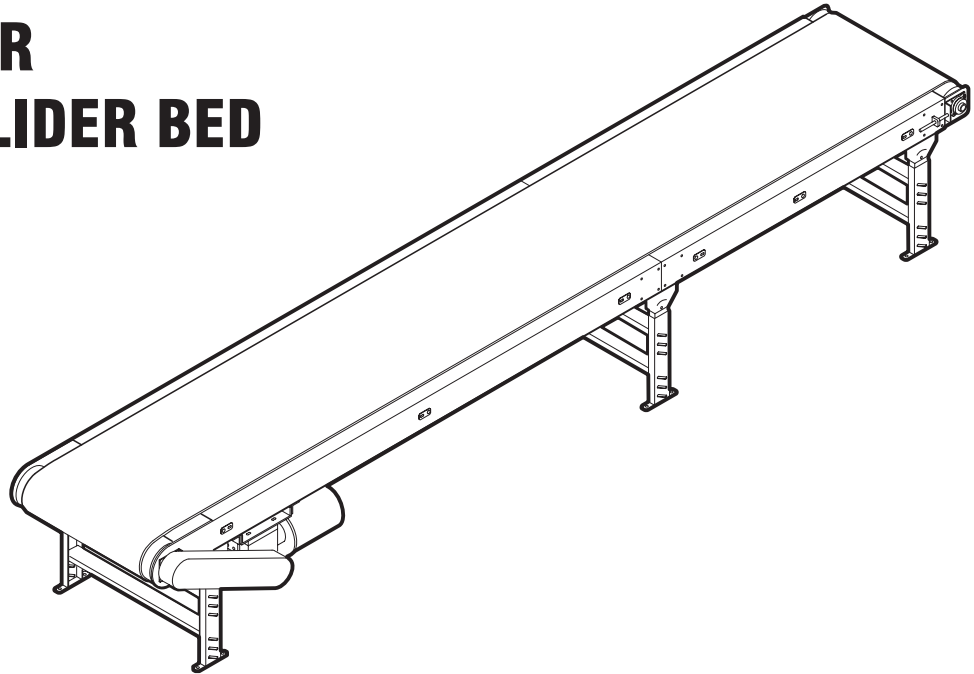

LOAD CAPACITY CHART	
Horizontal Conveyor Slider Bed @ 60 FPM	
HP	TOTAL LOAD
1/2	435 lbs.
3/4	650 lbs.
1	810 lbs.
1 1/2	1080 lbs.
2	1300 lbs.

Standard Specifications:

Belt - Black PVC-120 FS x FS with clipper lacing.

Belt Widths - 6 in., 8 in., 10 in., 12 in., 14 in., 16 in., 18 in., 20 in., 24 in., 30 in., and 36 in.

Tail Pulley - 6 in. Dia. with 1 7/16 in. dia. shaft.

Drive Pulley - 8 in. dia. crowned and fully lagged with 1 7/16 in. dia. shaft.

Return Rollers - 2 in. dia.

Snub Rollers - 2 in. Dia.

Bed - 11 ga. formed steel. 6 1/2 in. deep. Bed sections are 5 feet and 10 feet long bolted together with splice plates and floor supports.

Floor Supports - Adjustable 31 in. to 43 in. from floor to top of belt.

One support supplied at each end of conveyor and at each end of bed joint..

Take-Up - 6 in. long screws located at tail pulley to provide belt tension.

Motor - 1/2 H.P. 230/460/3/60 TEFC motor.

Speed Reducer - C-Face mounted heavy duty worm gear reducer.

Bearings - Sealed-prelubricated with cast iron housings.

Belt Speed - 60 FPM constant.

Capacity - Maximum load per linear foot of conveyor - 100 lbs. Not to exceed Load Capacity Chart.

Conveyor Bed Length "A"	Overall Length	Belt Width	6"	8"	10"	12"	14"	16"	18"	20"	24"	30"	36"
		Bed Width	12"	14"	16"	18"	20"	22"	24"	26"	30"	36"	42"
5'	6'4"	Weight (lbs.)	320	325	350	355	370	372	396	400	425	455	490
10'	11'4"		365	370	391	401	450	453	485	488	525	605	565
15'	16'4"		430	437	477	487	558	563	615	623	675	736	802
20'	21'4"		475	482	518	533	638	644	704	710	775	846	917
25'	26'4"		540	549	604	619	746	754	834	845	925	1017	1115
30'	31'4"		585	594	645	665	826	835	923	933	1025	1127	1230
35'	36'4"		650	661	731	751	934	945	1053	1068	1175	1298	1427
40'	41'4"		695	706	772	797	1014	1026	1142	1155	1275	1408	1542
45'	46'4"		760	773	858	883	1122	1136	1272	1290	1425	1579	1740
50'	51'4"		805	818	899	929	1202	1217	1361	1378	1525	1689	1855
55'	56'4"		870	885	985	1015	1310	1327	1491	1513	1675	1860	2052
60'	61'4"		915	930	1026	1061	1390	1408	1580	1600	1755	1970	2167
65'	66'4"		980	997	1112	1147	1498	1518	1710	1735	1925	2141	2365
70'	71'4"		1025	1042	1153	1193	1578	1599	1799	1823	2025	2251	2480
75'	76'4"		1090	1109	1239	1279	1686	1709	1929	1958	2175	2422	2677
80'	81'4"		1135	1154	1280	1325	1766	1790	2018	2045	2275	2532	2792
85'	86'4"		1200	1221	1366	1411	1874	1900	2148	2180	2425	2703	2990
90'	91'4"		1245	1266	1407	1457	1954	1981	2237	2268	2525	2813	3105
95'	96'4"		1316	1333	1493	1543	2062	2091	2367	2403	2675	2984	3302
100'	101'4"		1355	1378	1534	1589	2142	2172	2456	2490	2775	3094	3417
105'	106'4"	1420	1445	1620	1675	2250	2282	2586	2625	2925	3265	3615	
110'	111'4"	1465	1490	1661	1721	2330	2363	2675	2713	3025	3375	3730	
115'	116'4"	1530	1557	1747	1807	2438	2473	2805	2848	3175	3546	3927	
120'	121'4"	1575	1602	1788	1853	2518	2554	2894	2935	3275	3656	4042	
125'	126'4"	1640	1669	1874	1939	2626	2664	3024	3070	3425	3777	4240	
130'	131'4"	1685	1714	1915	1985	2706	2745	3113	3158	3525	3937	4355	

How To Order

Model: XXXX-XX-XXXX-XXX-XXX-XXX-XXX-XX-XXX-XX

<p>Model / Series: (SB400) Slider Bed (SB650) Slider Bed (TSB250) Slider Bed</p> <p>Belt widths: (06) = 6", (08) = 8", (10) = 10", (12) = 12", (14) = 14", (16) = 16", (18) = 18", (20) = 20", (24) = 24", (30) = 30"</p> <p>Belt Type: (STD) = Standard per catalog specifications (SPE) = Special requirements will need to be specified at the time of estimating</p> <p>Drive Pulley Diameter: (04) = 4" dia. (std. For SB 400, TSB250) (06) = 6" dia. (Std. For SB650) (08) = 8" dia.</p> <p>Overall conveyor length: Refer to length selection table (ex: (0510) = 5'-10")</p> <p>Supports: (Top of Bed / Top of Roller height) (STD) = Standard supports 28 1/2" to 40 1/2" (NSP) = No supports required ** If not standard please use top of bed / top of roller height dimensionally (ex: (12) = 1'-0" or (046) = 3'-10")</p>	<p>Paint color (01) Blue, (02) Crème, (03) Safety Yellow, (04) Safety Orange, (05) Med. Metallic Grey, (06) White, (07) Dark Blue</p> <p>Drive position: (DLU) Left Hand, Mounted Low (Included in std. prc) (DRU) Right Hand, Mounted Low (Included in std. prc) (DLH) Left Hand, Mounted High (Add to std. price) (DRH) Right Hand, Mounted High (Add to std. price) (DLC) Left Hand, Center Mount (Add to std. price) (DRC) Right Hand, Center Mount (Add to std. price)</p> <p>Denotes horse power requirements: (05) 1/2 HP (Included in Standard pricing) (75) 3/4 HP (Add to std. price) (10) 1 HP (Add to std. price) (15) 1 1/2 HP (Add to std. price)</p> <p>Denotes F.P.M. (Feet Per Minute) requirements. Std. 60 F.P.M. (Selection from 30 F.P.M. to 200 F.P.M. in increments of 10 F.P.M.)</p> <p>Guiding: (NGS) = No guides required (STD) = Formed guides ** For special guiding please refer to guide catalog supplement for part number)</p>
--------------------------------------------------------------------------------------------------------------------------------------------------------------------------------------------------------------------------------------------------------------------------------------------------------------------------------------------------------------------------------------------------------------------------------------------------------------------------------------------------------------------------------------------------------------------------------------------------------------------------------------------------------------------------------------------------------------------------------------------------------------------------------------------------------------------------------------------------------------------------------------------------------------------	-------------------------------------------------------------------------------------------------------------------------------------------------------------------------------------------------------------------------------------------------------------------------------------------------------------------------------------------------------------------------------------------------------------------------------------------------------------------------------------------------------------------------------------------------------------------------------------------------------------------------------------------------------------------------------------------------------------------------------------------------------------------------------------------------------------------------------------------------------------------------------------------------------------------------------------------------------------------------------------------------------------------------------------------

How To Order

Optional Equipment:

Belt - Neoprene friction surface (white or black); Neoprene with smooth top cover (white or black); Ruff top, black rubber, red Neoprene. Special belts on application.

Floor Supports - Lower or higher than standard. Castered supports with 4 in. dia. or 6 in dia. rigid or swivel caster.

Ceiling Hangers - Threaded rods 8 feet long with locking nuts and mounting hardware. Other lengths are available.

Center Drive - Mounted below conveyor bed section. Can be placed anywhere in conveyor length.

Side Mounted Drive - End drive mounted to side of conveyor section. Specify side.

Overhead Drive - End drive mounted above conveyor. Specify clearance required.

Auxiliary Take-Up - Mounted below conveyor bed section. Can be placed anywhere in conveyor length.

Motor - Single phase, totally enclosed, explosion proof, etc. Other H.P. are available.

Belt Speed - Constant and variable belt speeds available.

Electrical Controls - Magnetic starters, push button stations, manual one direction and reversing drum switches and others.

Guard Rails - Adjustable channel, continuous channel, or solid steel guard rails available.

Gravity Conveyor Brackets - Adjustable bracket with 1 3/8 in. dia. pop-out roller for attaching wheel or roller conveyor.

Nose-Over - Adjustable single or double nose-over provides smooth transfer from incline to horizontal.